

# VisualFAIR® - Completion Check Sheet

FAI Report Number: OCRI2333/001

Part Number: OCRI2333  
Part Revision Level: B  
Drawing Number: OCRI2333  
Drawing Revision Level: B  
FAIR Style: Rolls-Royce

IPI Solutions Ltd  
info@ipi-solutions.co.uk  
Tel: +44 (0)121 285 0285  
Fax: +44 (0)121 772 3103



## Mark-up

Present : **Ballooned Print**      **Ballooned Features : 7**      **Features with no values : 2**      **Features with no result(s) : 5**      **Features in tolerance : 1**      **Features out of tolerance : 1**

## Forms

Present : 9102_1	3 required values missing	3 conditionally required	5 optional
Present : 9102_2	2 required values missing	2 conditionally required	1 optional
Present : 9102_3 Gauge	2 required values missing	2 conditionally required	1 optional

## Signatures

9102_1	Signature 1	Signature 2
9102_2	Signature 1	
9102_3 Gauge	Signature 1	

IPI Solutions Ltd

## Ad-hoc Attachments

Missing : **Additional Information**  
**Non-conformance report for feature 2 - reference location 5C**      **Incomplete**

## Materials, Processes Functional Testing

**RPS54 - Rev 2 (anodise)**      **Complete**

THIRD ANGLE PROJECTION

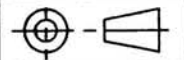

ANODISE ALL OVER TO SPEC. A  
DIMENSIONS APPLY AFTER ANODISING

INSPECT AND ACCEPT TO SPEC. B

S1

B

C

D

E

F

G

H

J

K

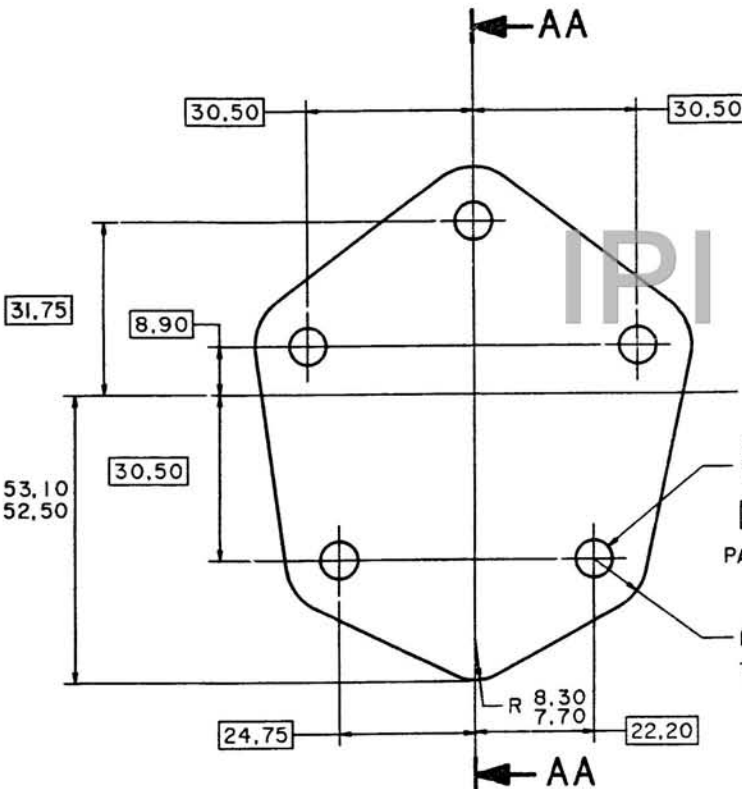

5 HOLES  
Ø 7.46  
7.20  
Ø 0.40 M A  
PART ID LOCATION  
R 10.30  
9.70  
TYP 5 CORNERS

R 0.30 TYP 2 POS  
0.10  
62° TYP 2 POS  
58  
R 0.70 TYP 2 POS  
0.30

VIEW AT AB  
SCALE 5:1

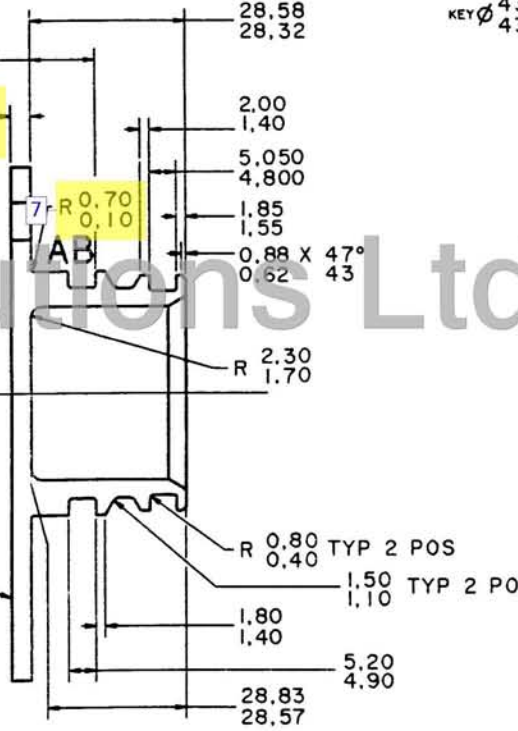

SECTION AA

(G6)

IDENTITY MARKINGS HERE

ISSUE/CHANGES				
ISSUE STATUS	ZONE	DESCRIPTION	DATE	AUTHORITY
A	ALL			
B	ALL			

NON-DESTRUCTIVE TEST INSP.	
MATERIAL SPEC/CODE	
HARDNESS VALUE	NONE
HARDNESS TESTING	
HEAT TREATMENT	NONE
IDENTITY MARKINGS	
SCREW THREADS	NONE
SURFACE TEXTURE	
DRAWING PRACTICE AND TOLERANCE INTERPRETATION	
GENERAL SPECIFICATIONS	

ANGLES ARE IN DEGREES AND DECIMAL PARTS OF A DEGREE  
MACHINE ALL OVER  
UNLESS OTHERWISE SPECIFIED :-  
ALL DIMENSIONS IN MILLIMETRES  
TOLERANCE ON DIMENSIONS ± 0,30  
TOLERANCE ON ANGLES ± 2°  
SURFACE TEXTURE VALUES IN MICROMETRES  
SURFACE TEXTURE TO BE 1,6 (—)  
SHEET ITEMS—REMOVE BURRS AND BREAK SHARP EDGES  
OTHER ITEMS—BREAK SHARP EDGES 0,30 ± 0,20  
SIMILAR PART REFERENCE

DRAWN	
SITE	
DATE	
CHECKED	
LAB/MDT/WELD	
APPROVED	

SECURITY/PRIVACY CLASSIFICATION	UNCLASSIFIED
PART NAME	COVER
DRAWING NUMBER	OCR12333
ORIGINAL SCALE	2:1
SHEET 1 OF 1 SHEETS	









Chemical Processing  
Coatings  
N.D.T



ISO 9001:2000  
AS/EN 9100  
FM 00235



**ABBEY METAL FINISHING COMPANY LIMITED**

Weddington Road, Nuneaton, Warwickshire CV10 0AJ  
Telephone: 024 7635 0444 Fax: 024 7664 1299 E Mail: admin@amfin.co.uk



Approval No A/194

**CUSTOMER ADDRESS:**

Monta Limited  
Whitacre Road  
Nuneaton  
Warke  
V11 6BX

NOTE NO.	DATE
246955	17 4/05

Rolls - Royce Approval No. 1253  
BA Systems Approval No. BAe/AG/10050/AERO

**COMPONENT DETAILS**

WIP No. 326542  
AS9529  
(Cover)

**PROCESS DETAILS**

Order No. 25303  
Rel. Note No. 40914  
Chromic anodised all over to RP55473.  
APR 25  
APR 27  
BATCH COMPLETE  
COMMENTS  
JOB NO. 26567

DELIV

Solutions Ltd

*A Brown*  
**A BROWN**

04 APR 2005

Received

**APPROVED CERTIFICATE**

Certified that unless otherwise stated above, the whole of the above mentioned parts have been processed and-inspected in accordance with the terms of the order applicable thereto and conform fully to the standards/specifications quoted thereon and the requirements of the Civil Aviation Authority.

Signed.....  
For and on behalf of  
Abbey Metal Finishing Co. Ltd.

**CERTIFICATE OF CONFORMANCE**

Certified that the supplies/services detailed hereon have been inspected and tested in accordance with the conditions of the and unless noted above conform in all respects to the relevant specifications/drawings and have accord with the requirement

\* BAE SYSTEMS  
BAe/AG/OC/SCI Part  
\* AIRBUS UK  
AUK/SA/001-1  
\* MESSIER-DOWTY  
P.R.I.D.E.  
\* BSI  
BS EN ISO 9001:2000  
AS EN 9100  
\* Rolls Royce  
RR9000 : SABRE  
\* GOODRICH  
981-151-001  
\* TICK ACCORDINGLY

Signed.....  
For and on be  
Abbey Metal Fini!

## VisualFAIR® - Index

---

Completion Check Sheet	1
OCR12333 iss B (Drawing)	2
9102_1 (Form)	3
9102_2 (Form)	4
9102_3 Gauge (Form)	5
Process CofC.jpg (Material/Process)	6
Non-conformance report for feature 2 (Attachment) could not be printed	

# IPI Solutions Ltd